

Anti-Lock Brake System (ABS) Module

Anti-Lock Brake System (ABS) Module

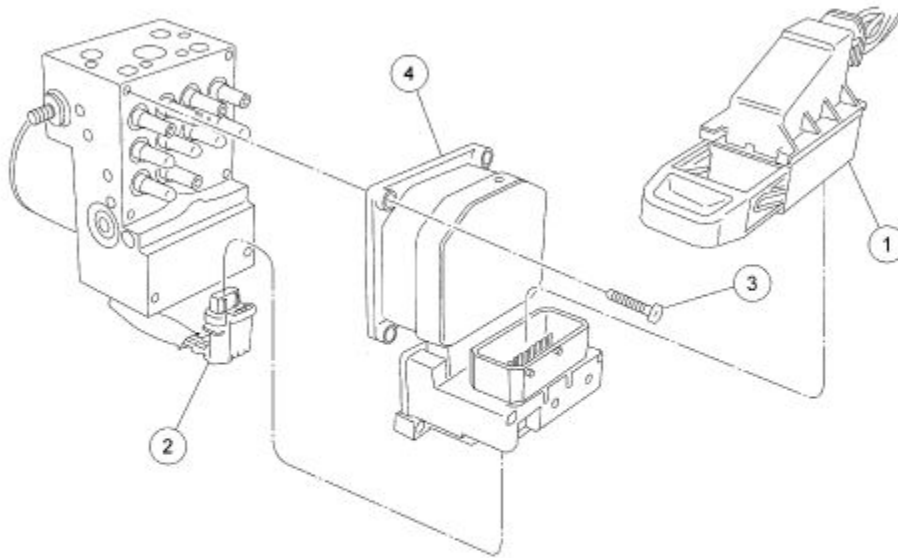

N0040524

Item	Description
1	Anti-lock brake system (ABS) module electrical connector
2	Hydraulic control unit (HCU) pump motor electrical connector
3	ABS module screw (6 required)
4	ABS module

Removal and Installation

1. Remove the air cleaner. For additional information, refer to Fuel Delivery and Air Induction.
2. Disconnect the battery ground cable. For additional information, refer to Battery.
3. Disconnect the anti-lock brake system (ABS) module electrical connector.
4. Disconnect the hydraulic control unit (HCU) pump motor electrical connector.
5. **NOTE:** Care must be taken when removing the module from the hydraulic control unit (HCU).

Remove the ABS module.

- Remove the screws in the sequence shown.
- To install, tighten to **3 Nm (27 inch lbs.)**.

6. **NOTE:** Make sure that the ABS module-to-HCU gasket surfaces are clean and that the gasket is

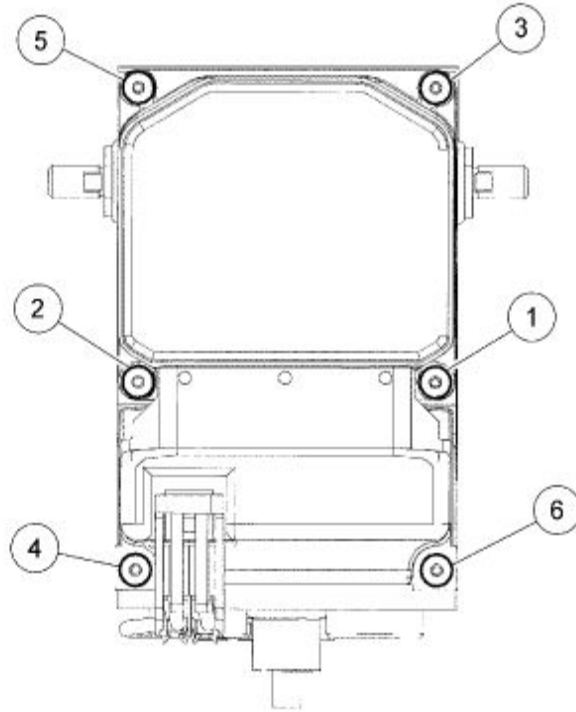

correctly installed. N0040557