

# CADILLAC CATERA ABS REMOVAL INSTRUCTIONS

## Removal Procedure

**Notice:** To prevent equipment damage, never connect or disconnect the wiring harness connection from the EBCM with the ignition switch in the ON position.

**Notice:** Avoid getting water, brake fluid or engine coolant into the socket of the EBCM/EBTCM connector. Failure to observe this precaution could result in damage to the EBCM/EBTCM.

1. Turn the ignition switch to the OFF position

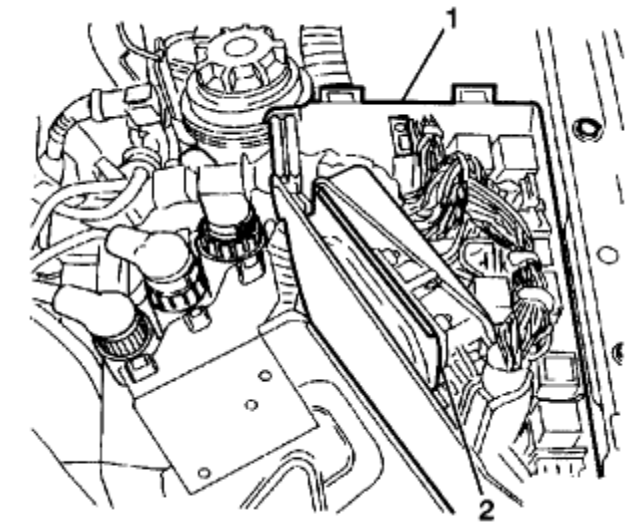

2. Remove the cover from the relay center (1).
3. Remove the Engine Control Module (ECM) (2) from the relay center (1). Move the **ECM** harness to one side.
4. Remove the lower radiator hose from the engine only. Refer to Radiator Hose Replacement - Outlet in Cooling System. Move the radiator hose to one side.

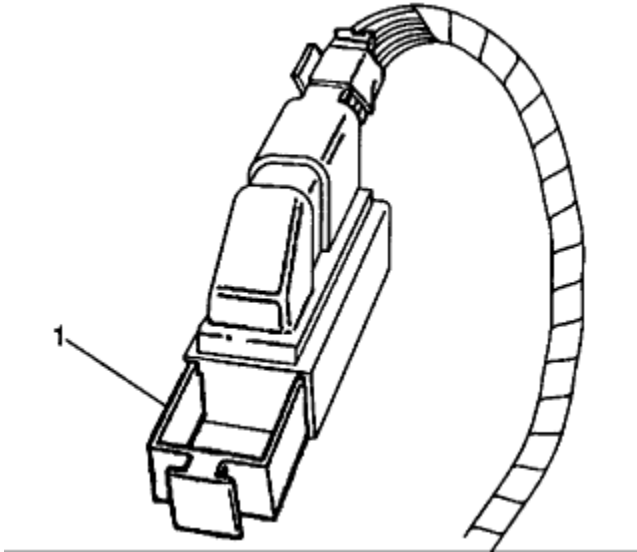

5. Pull out lock tab from the EBTCHM harness connector (1).
6. Disconnect the EBTCHM harness connector.

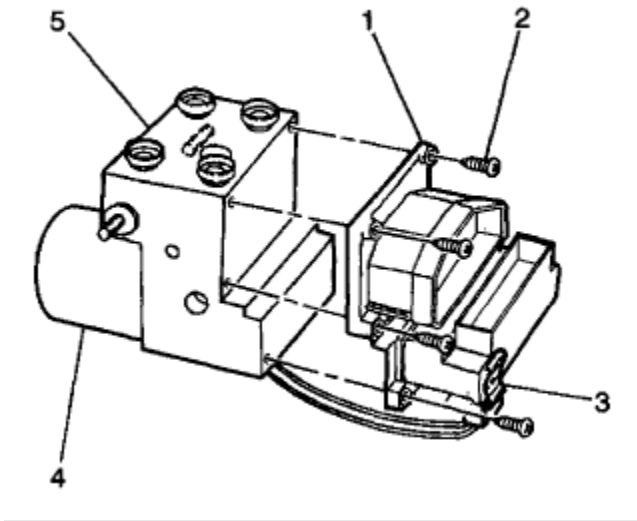

7. Disconnect the pump motor connector (3) at the bottom of the EBTCHM.
8. Remove the six EBTCHM to BPMV screws (2).  
Be careful not to damage seal. Do not pry apart using a tool.  
Important: Care must be taken not to damage the solenoid valves when the EBTCHM is removed from the BPMV
9. Separate the EBTCHM (1) from the BPMV (5) by gently pulling apart until separated